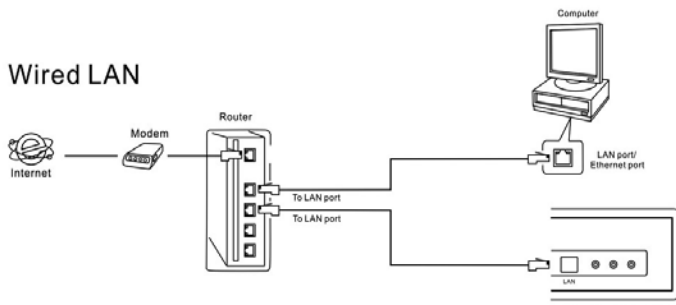
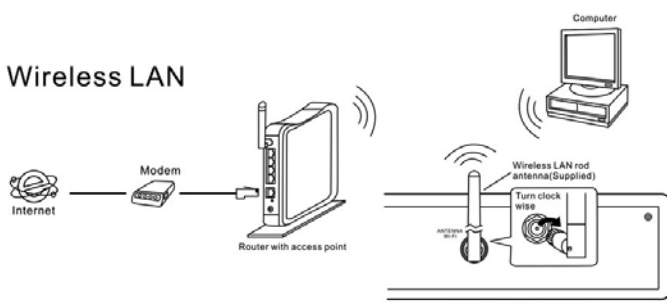

Quick Setup Guide

Connect the Sangean Internet Radio (WFR-1) either to wired or wireless LAN as shown below. This is the same way your PC is connected to the internet.

* No PC is needed. PC needs to be turned on and connected to the router only when you would like to play music loaded in your PC (Shared Folder or UPnP).

Wired LAN	Wireless LAN
 <ol style="list-style-type: none">1. Turn on the router and the internet radio.2. Connect the devices as the figure above.3. Rotate and press the SELECT control (a knob) on the radio to go to Main Menu -> System Setup -> Internet Setup -> Wizard -> [Wired]4. If there is password for the access point, input and enter the password using the SELECT control. Then radio will connect to the internet. Please read the instruction manual for all the functions. <p>* If the wired connection is not working, after a few seconds the display will change to show 'Scan for networks'</p>	 <ol style="list-style-type: none">1. Turn on the router with access point and power plug the internet radio.2. Connect the devices as the figure above.3. Press the SELECT control (a knob) on the radio, it will scan for networks and show all the detectable access points' names.4. Rotate and press the SELECT control to select your access point. It can be your access point's model name or a set up name.5. If there is password for the access point, input and enter the password using the SELECT control. Then radio will connect to the internet. Please read the instruction manual for all the functions.

* After setting up as above, the internet radio is connected to internet and ready to be operated. Rotate and press the turning knob on the internet radio to operate the functions.

PROBLEMS:

CALL TOLL FREE 1-888-SANGEAN (726-4326)

Troubleshooting

If you have difficulty connecting the radio to your wireless network, some of these steps may help to resolve the problem:

Problem	Cause	Suggestion
The display shows “Network Error” or it times out after it shows “Network Error for a long period of time.	Network is not connected	Check if the router/modem is powered on, and check if the wireless access point you connected is correct.. For wired connection, check if the Ethernet is plug in to the internet radio.
Can’t connect to the networks	You have a static IP address	You can configure a static IP address on the radio using the menu item ‘Main Menu -> System Setup -> Internet Setup -> Wireless or Wired(select one you are using) ->, and then select DHCP disable’, to input your IP ,DNS addresses.
When the unit is using wireless, the display shows “Please wait connecting ”	Network bandwidth/speed is insufficient	Internet radio consumes 32kbps to 256 kbps. Dial up connection doesn’t work with internet radio. Cable, ADSL or fiber are all good.
	Wireless router blocks the internet radio MAC address	Check that your access point does not restrict connections to particular MAC addresses. You can view the radio’s MAC address by checking the direction of ‘Main Menu -> System Setup -> Internet Setup ->View Settings’. Note that the this internet radio has both wired and wireless MAC addresses.
	There is no wireless connection	Check if: <ol style="list-style-type: none"> 1. The router/modem is on 2. The unit is too far from the wireless access point. 3. Check with laptop, if available, to make sure wireless is operating correctly.
Internet radio can’t be played	Radio station is not broadcasting, or the station has reached the maximum allowed number of listeners.	Select another radio station.
Sound is on and off	Network bandwidth/speed is slow	It may happen when listening to high bit rate station, or the network bandwidth is occupied.