

SANGEAN

SG-108

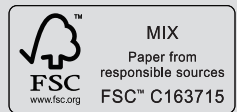

3A811W0530030

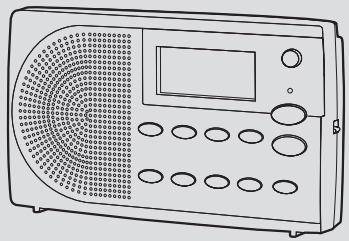
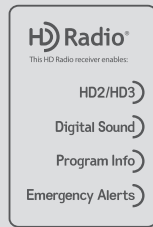
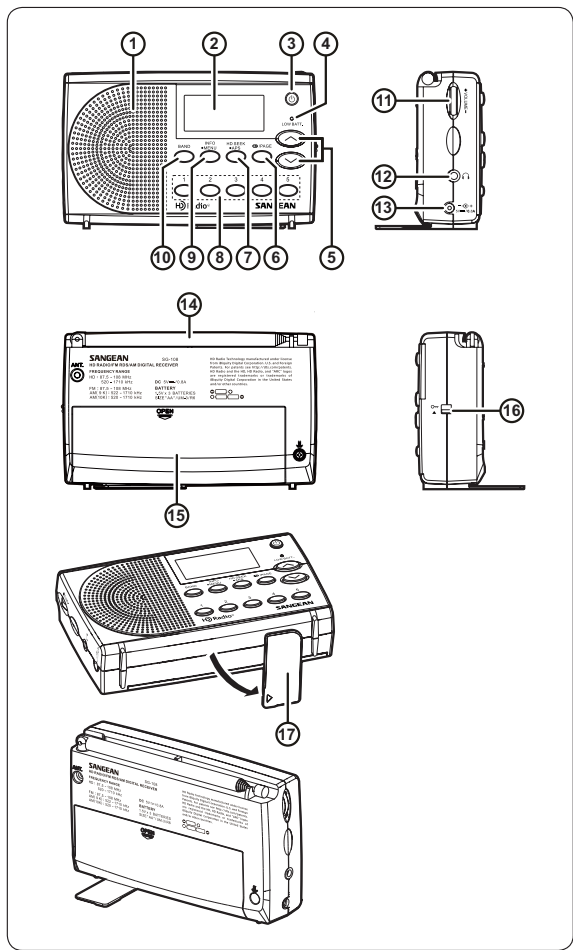

06

Note: When in "Auto" mode, the menu cannot be set if using batteries and the radio is switched off.

Scan tuning FM / AM

1. Make sure the telescopic antenna is fully extended in advance.
2. Press the Power button to switch on your radio.
3. Press the Band button repeatedly to select the desired frequency band.
4. To scan up in frequency, press and hold the Tuning up button. Your radio will scan in an upwards direction (low frequency to high frequency) and stop automatically when it finds a station of sufficient strength. To scan down in frequency, press and hold the Tuning down button. Your radio will scan in a downwards direction and stop automatically when it finds a station of sufficient strength.
5. After a few seconds the display will update. The display will show the frequency of the signal found. If the signal is strong enough and there is RDS / RBDS data present then the radio will display the station name.

Manual tuning – FM / AM

1. Press the Power button to switch on your radio.
2. Press the Band button repeatedly to select the desired frequency band.
3. Press and release the Tuning up / down button to tune to a station. The frequency will change in steps of 50kHz / 100kHz / 200kHz in FM or 9kHz / 10kHz in AM.
4. When the frequency band end is reached the radio will recommence tuning from the opposite frequency band end.
5. Adjust the Volume control to the desired volume settings.
6. To switch off your radio press the Power button.

Note: If your radio has any interference in the AM band because of its adaptor, please move your radio away from its AC adaptor at least 12".

Presetting stations

There are 20 presets (4 pages x 5 presets) each for FM and AM radio. They are used the same way for each operating mode.

13

b. HD Radio™ status

Press and release the Info button to cycle through the various options.

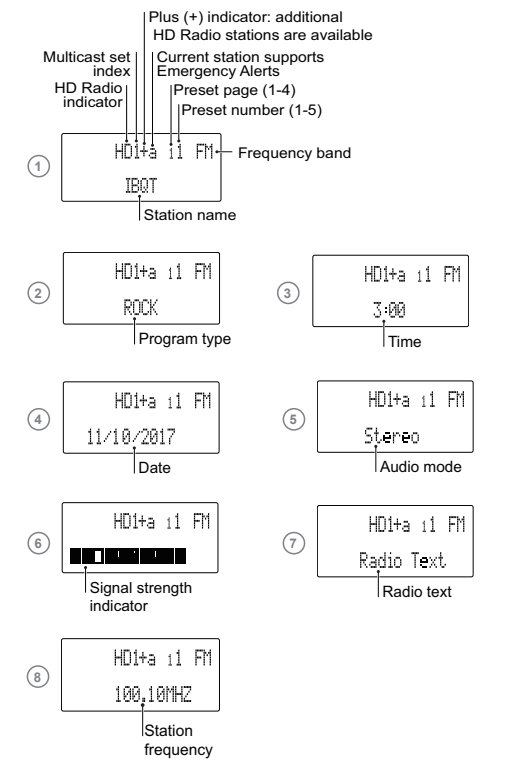

07

1. Press the Power button to switch on your radio.
2. Tune to the required radio station as previously described.
3. To store the station as a preset, press the Page button to select the required preset page 1 to 4 and press and hold the required preset button (1-5) until you hear a beep and the display will show the page and the memory pre-set you selected, e.g. "21".
4. Stations which are already stored in the presets may be overwritten by following the above procedure.

Recalling a preset station

1. Press the Power button to switch on your radio.
2. Select the required operating mode using the Band button.
3. Press the Page button to select the required preset page and momentarily press the required Preset button, your radio will tune to the station stored in the selected preset memory. The chosen preset number is shown in the upper right hand side of the radio display, e.g. "21".

Stereo / Mono switching

If the FM radio station being listened to has a weak signal, some hiss may be audible. It is possible to reduce this hiss by forcing the radio to play the station in mono rather than stereo.

1. Press the Power button to switch on your radio.
2. Press the Band button as needed to select the FM radio mode and tune to the desired FM station as previously described.
3. Press and hold the Menu button to enter the menu setting and then press the Tuning up / down button to select "Force Mono". Press the Select button to enter the setting.
4. Press the Tuning up / down button to select the "Mono" or "Stereo". Press the Select button to confirm the setting.

Note: FM stereo is only available via earphones or in HD Radio mode.

Tuning region

Your radio can be configured for any one of the four international tuning regions.

1. Press the Power button to switch on your radio.

14

Setting the alarm clock

Your radio has 2 separate alarms which can be set to wake you to FM, AM or buzzer. Each alarm can be set to sound once, daily, on weekdays or weekends. Ensure that the time is set correctly before setting the alarms.

Note: When the submenu of "Clock on Standby" is set to "Auto" option, the alarms can't be set if using batteries and the radio is switched off.

Note: If no buttons are pressed for 10 seconds, the radio will exit the alarm setup.

1. Press and hold the Menu button to enter the menu setting and then press the Tuning up / down button to select "Alarm 1" (or "Alarm 2"). Press the Select button to enter the setting. (**Note:** If the time is not set before setting the alarms, "Time is not set" will show on the display. Use the Tuning up / down button and Select button to set the time and date. When the setting is complete, proceed to step 2.)
2. Press the Tuning up / down button to select "On" or "Off". If "Off" is selected any current setting for that alarm will be cancelled. With "On" selected, press and release the Select button to enter the "A1 time" (or "A2 time") setting. The alarm hour digits will flash on the display.
3. Press the Tuning up / down button to choose the desired hour for the alarm and press the Select button to cause the minute digits to flash on the display.
4. Press the Tuning up / down button to choose the desired minute for the alarm and press the Select button to confirm the setting. The display will show the frequency options for the alarm.
 - "Daily"-the alarm will sound everyday.
 - "Weekends"-the alarm will sound only on weekends.
 - "Weekdays"-the alarm will sound on weekdays only.
 - "Once"-the alarm will sound only once.
5. Press the Tuning up / down button to select your required frequency and press the Select button to confirm your setting.
6. Press the Tuning up / down button to choose the desired source for the alarm (Buzzer, FM or AM). Press the Select button to confirm the setting. If setting alarm to Buzzer proceed to step 7.
7. When selecting the alarm for FM or AM, press the Tuning up / down button to choose the preset page (1-4) and press the desired preset button (1-5). Press the Select button to allow the frequency to flash on the display. If this frequency is your desired wakeup station, press the Select button to confirm your selection. If you wish to change the frequency or the selected preset is empty, press the Tuning up / down button to choose your required station and press the Select button to confirm the selection. The alarm has now been set. Adjust the Volume control to set your required volume level.

01

GB Operating instruction



HD Radio Technology manufactured under license from iBiquity Digital Corporation, U.S. and Foreign Patents. For patents see <http://fdts.com/patents>. HD Radio and the HD, HD Radio, and "ARC" logos are registered trademarks or trademarks of iBiquity Digital Corporation in the United States and / or other countries.

For United States:

FCC Cautions to the user

The changes or modifications not expressly approved by the party responsible for compliance could void the users authority to operate the equipment.

The equipment has been tested and found to comply with the limits for a Class B Digital Device, pursuant to part 15 of the FCC Rules. These limits are designed to provide reasonable protection against harmful interference in a residential installation. This equipment generates, uses and can radiate radio frequency energy and, if not installed and used in accordance with the instruction, may cause harmful interference to radio communication. However, there is no guaranty that interference will not occur in a particular installation. If this equipment does cause harmful interference to radio or television reception, which can be determined by turning the equipment off and on, the user is encouraged to try to correct the interference by one or more of the following measures:

- Reorient or relocate the receiving antenna.
- Increase the separation between the equipment and receiver.
- Connect the equipment into an outlet on a circuit different from that to which the receiver is connected.
- Consult the dealer or an experienced radio / TV technician for help.

CAUTION: These servicing instructions are for use by qualified service personnel only. To reduce the risk of the electric shock, do not perform any servicing other than that contained in the operating instructions unless you are qualified to do so.

VERY IMPORTANT PLEASE READ

Sangean suggest that you keep your AC Adapter at least 12 inches away from the radio while listening to the AM Band.

Your Sangean Radio is powered by an AC adapter which is a "switching" or "switch-mode" type. The DOE (Department Of Energy) has a Federal mandate, requiring all manufacturers to use this type of power supply.

08

2. Press the Band button to select your required frequency band.
3. Press and hold the Menu button to enter the menu setting and then press the Tuning up / down button to select "Region". Press the Select button to enter the setting.
4. Press the Tuning up / down button to select your required tuning region and then press the Select button to confirm your selection.

Region A (Most countries)	FM: 87.5-108, 100kHz
Region A (Philippines, Romania)	AM: 522-1710, 9kHz
Region B (US, Mexico, Canada)	FM: 87.5-107.9, 200kHz
Region B (US, Mexico, Canada)	AM: 520-1710, 10kHz
Region C (Most countries)	FM: 87.5-108, 50kHz
Region C (SE Asia)	AM: 522-1620, 9kHz
Region D (Brazil, Japan)	FM: 76-108, 100kHz
Region D (Brazil)	AM: 522-1629, 9kHz

Note: Resetting the tuning region will erase your preset stations stored in the radio. The memory presets will revert to the factory default settings.

Receiving HD Radio™ stations

When the radio is tuned to an HD Radio station, the HD Radio logo will flash in the display, indicating that the signal is blending from analog to digital. Once the receiver acquires the HD Radio signal, the HD Radio logo will remain solid on the screen.

Receiving Multicast Stations

When the radio is tuned to an HD Radio station, it will determine that one or more Multicast stations are available and "HD1+", for example, may appear on the display. "HD1" indicates the number of the current multicast program and plus (+) means that additional HD Radio programs are available. Press the Tuning up / down button on the radio to tune to HD2 / HD3 Multicast channel.

HD SEEK function

Using the HD Seek button, the radio will seek to the next available HD Radio station. This function will also scan to the Multicast program if available. Pressing and releasing the HD Seek button will tune to the next available HD

15

7. Press the Tuning up / down button to choose your desired volume and press the Select button to confirm the setting. Your radio will show "Alarm 1 Saved" (or "Alarm 2 Saved") and exit the alarm setting screen. The symbol "A" will show on the top right corner of the screen.
8. To view the status of the alarm setting, press and hold the Menu button to enter the menu setting and then press the Tuning up / down button until "Alarm 1" (or "Alarm 2") is shown on the display. You can view the status of the alarm setting on the display.

When the alarm sounds

To cancel a sounding alarm, press the Standby button to cancel a sounding alarm.

When the buzzer alarm activates, the alarm will start softly and gradually increase in level. It will sound for 1 minute and silence for 1 minute in repetition for 60 minutes unless cancelled.

When the radio alarm is activated, the alarm will go off in Humane Waking System. It will increase its volume from 0 to your set volume.

The symbol "A1" or "A2" will show on the display when the Alarm 1 or Alarm 2 is activated.

Disabling / canceling alarm setting

To cancel the alarm setting before the alarm sounds, press and hold the Menu button to enter the menu setting and then press the Tuning up / down button until "Alarm 1" (or "Alarm 2") is shown on the display. Press the Select button and press the Tuning up / down button to select "Off" and press the Select button to confirm the setting.

Snooze

The buzzer or radio alarm can be silenced for 5 minutes by pressing any button other than the Power button. In order to cancel the Snooze timer while the alarm is suspended, press the Power button.

Sleep timer

Your radio can be set to turn off after a preset time has elapsed. The sleep timer setting can be adjusted between 15 and 180 minutes.

1. Press the Power button to switch on your radio. Press and hold the Menu button to enter the menu setting and then press the Tuning up / down button to select "Sleep Time". Press the Select button to enter the setting.
2. Press the Tuning up / down button to select the desired sleep time. The options are Off, 15,30,60,90,120,150,180. Press the Select button to confirm the setting. Use the Off option to cancel the sleep function.

02

This newer power saving technology has the unfortunate side effect of causing interference to the AM radio band.

Therefore, we recommend that customers keep at least a 1 foot distance between the AC adapter and the radio. This interference will not affect the FM Band. If you have any questions please contact customer service at (888)726-4326, (562)941-9900 or service@sangean.com If an AC adapter isn't included in this model and if you wish to purchase an AC Adapter separately, please refer to the specifications for the AC Adapter stated on the final page of the manual, or please contact Sangean for the correct AC Adapter and specifications.

To learn more about the DOE mandate please visit http://www1.eere.energy.gov/buildings/appliance_standards/product.aspx/productid/23 Please note not all AC adapters are alike.

The AC adapter that is included with this radio is designed to be used exclusively with this device. Do not use an AC adapter that differs from the specifications on the AC adapter that is included.

If an AC adapter is NOT included with your radio and in order not to damage the unit and void your warranty, specifications for the AC Adapter are stated on the final page of the manual, or please contact Sangean for the correct AC Adapter and specifications. For customers in the US and Canada, please call 562-941-9900 or 888-726-4326. For all other areas, please contact us via contact@sangean.com.

Do not use an AC adapter that does not meet the correct specifications.

Cautions

Do not allow this radio to be exposed to water, steam or sand. Do not leave your radio where excessive heat could cause damage such as in a parked car where the heat from the sun can build up even though the outside temperature may not seem too high.

- Your radio should not be exposed to dripping or splashing water and that no objects filled with liquids, such as vases, shall be placed on the radio.
- It is recommended to operate the product such that there is a minimum distance ("4" recommended) to adjacent objects in order to ensure good ventilation.
- The ventilation of the product should not be restricted by covering it or its ventilation openings with items such as newspapers, tablecloths, curtains etc.
- No open flame sources such as lighted candles should be placed on the product.
- It is recommended to avoid using or storing the product at extreme temperatures. Avoid leaving the unit in cars, on window sills or in direct sunlight etc.

09

Radio station of sufficient signal strength.

HD Radio™ (APS) Auto Preset System

This system will automatically scan and preset the received stations in the order of signal strength, i.e. best reception station will be preset at Preset 1 of Page 1 and so on. APS function is only available in the HD Radio FM / AM bands.

1. Press the Band button to select your required frequency band.
2. Press and hold the APS button to initiate scan. The radio will scan from the lowest frequency on the selected band, automatically storing stations in preset memory based on signal strength order. During the scanning process, as new stations are detected the station counter on the right hand side of the display will increase.

Note:

- The maximum number of presets is 20 (4 pages x 5 presets) each for HD Radio FM and AM band. If during APS operation more than 20 (HD Radio FM or AM) are found only 20 strongest stations will be stored in the preset memories.
- All previously stored preset stations will be erased when APS operation commences and HD Stations are found.
- To recall the preset station, press the Page button to select Page 1 to 4, and then press the preset numeric button.

Emergency alert (EA)

Emergency Alerts (EA) is a warning system used by broadcasters to notify listeners about potential hazardous situations related to extreme weather, floods, and infrastructure failures, amber alerts (child abductions), and more.

Your Radio must be in a location that allows for adequate reception of audio and data services and tuned to a station that provides the Emergency Alerts.

When enabled, the Emergency Alerts feature allows audio and text-based alerts to be played or displayed by the radio, the alerts can also awaken the radio from standby mode when using the AC adaptor.

Emergency alerts setting

1. Press and hold the Menu button to enter the menu setting and then press the Tuning up / down button to select "Alert". Press the Select button to enter the setting.
2. Press the Tuning up / down button to select "On" or "Off". To disable the Emergency Alerts feature, Select "Off" and then press the Select button to confirm the setting. With "On" selected, press the Select button to enter the Emergency Alerts Location setting.

16

Your radio will switch into standby mode after the preset time has elapsed.

An active sleep timer is shown using a symbol "S" on the playing display.

3. To cancel the sleep timer before the preset time has elapsed and to turn off the radio, press the Power button to turn the unit off manually. To cancel the sleep timer and leave the radio playing, go back to the sleep timer settings (step 1 to 2) and select the Off option in step 2.
4. To view the remaining time of an active sleep timer setting, press and hold the Menu button to enter the menu setting and then press the Tuning up / down button until "Sleep time" is shown on the display. You can view the remaining time of an active sleep timer on the display.

Contrast

The contrast of the display can be adjusted.

1. Press and hold the Menu button to enter the menu setting.
2. Press the Tuning up / down button to select "Set Contrast" and press the Select button to enter the setting.
3. Press the Tuning up / down button to adjust the contrast. The contrast level indication on the screen will change at the same time. When you find the setting that gives the best legibility for the location in which the radio is used, press the Select button to save the setting.

Language

Your radio can be configured to a different language.

1. Press and hold the Menu button to enter the menu setting and then press the Tuning up / down button to select "Language". Press the Select button to enter the setting.
2. Press the Tuning up / down button to select your required language.
3. Press the Select button to confirm your selection. The display will change to the chosen language.

Headphone socket

A 3.5mm Headphone socket located on the left hand side of your radio is provided for use with headphones.

Inserting headphones automatically mutes the internal loudspeaker.

Please be aware that the sensitivity of headphones can vary widely. We therefore recommend setting the volume to a low level before connecting headphones to the radio.

03

Controls

- ① Speaker
- ② LCD display
- ③ Power button
- ④ Low battery indicator
- ⑤ Tuning up / down button
- ⑥ Select / Page button
- ⑦ HD Seek / APS button
- ⑧ Preset 1-5
- ⑨ Info / Menu button
- ⑩ Band button
- ⑪ Volume control
- ⑫ Headphone socket
- ⑬ DC IN socket
- ⑭ Telescopic antenna
- ⑮ Battery compartment
- ⑯ Lock switch
- ⑰ Swivel stand

If needed, when the antenna is fully extended you can stabilize the radio using the swivel stand located on the bottom of your radio by following the above diagram.

Battery operation

1. Open the battery cover on the rear of the unit by pushing the latch downward.
2. Insert 3 x UM-3 / R6 (AA size) batteries into the battery compartment. Ensure the batteries are inserted with correct polarity as shown on the rear cabinet. Close the battery cover.
3. Reduced power, distortion and a stuttering sound or the low battery LED indicator is red are all signs that the batteries need replacing. If the radio is not to be used for an extended period of time, it is recommended that the batteries be removed from the radio.

10

3. Press the Tuning up / down button to select your required location setting. If you choose "Off", all the alerts that are broadcast within the radio's range will be received. The default setting is "Off". Press the Select button to confirm the setting.

If you choose "On", you can define the location, then the receiver will display text alerts (or awaken the radio from standby mode) only when the received data includes location-matching alerts. If location data is not included in the received data, then the receiver disregards the locations that are defined in the receiver. Press the Select button to confirm the setting.

4. The location preset "1" (for example) will flash on the top right corner of the screen. Now choose your required location preset you would like to setup. Press the Tuning up / down button to select your required location preset and press the Select button to confirm your selection. Up to 10 locations can be saved.
5. There are three options for Alert Location: State / County, Zip and Off. Press the Tuning up / down button to select your desired Alert Location option and then press the Select button to enter the setting.

If State / County was selected:

- (1) Press the Tuning up / down button to change the State and press the Select button to confirm the setting.
- (2) Press the Tuning up / down button to change the County and press the Select button to confirm the setting.
- (3) Press the Tuning up / down button to select "Save" or "Back". To confirm the setting, select "Save" and press the Select button to save the setting. To change the setting, select "Back" and press the Select button to change your setting.

If Zip was selected:

- (1) The first digit of your US Zip code will flash on the display. Press the Tuning up / down button to select the desired digit and press the Select button to cause the next digit to flash on the display. Continue to change all the digits in your Zip code. Press the Select button to confirm the setting.
- (2) Press the Tuning up / down button to select "Save" or "Back". To confirm the setting, select "Save" and press the Select button to save the setting. To change the setting, select "Back" and press the Select button to change your setting.

If Off was selected, the current Location preset will be disabled. Press the Select button to confirm the setting. Press the Tuning up / down button to select "Save" or "Back". To confirm the setting, select "Save" and press the Select button to save the setting. To change the setting, select "Back" and

17

IMPORTANT:

- Excessive sound pressure from earphones and headphones can cause hearing loss.
- To prevent possible hearing damage, do not listen at high volume levels for long periods.

Software version

The software version display cannot be altered and is just for your reference. Press and hold the Menu button to enter the menu setting. Then press the Tuning up / down button to select "Version" and you can view the software version on the display.

Reset the radio

If your radio fails to operate correctly or some digits on the display are missing or incomplete, please carry out the following procedure.

1. Press and hold the Menu button to enter the menu setting.
2. Press the Tuning up / down button to select "Factory Default" and press the Select button to enter the setting.
3. Press the Tuning up / down button to select "Yes" or "No". If you do not wish to cancel out a system reset, select "No" and then press the Select button to confirm the setting.
4. With "Yes" selected, press the Select button. A full reset will be performed. The radio will erase all saved settings and all settings will revert to the factory default settings. In case of malfunction due to electrostatic discharge, reset the product (reconnection of the power source may be required) to resume normal operation.

Lock Switch

The lock switch is used to prevent unintentional operation of the radio.

Set the Lock switch located on the right hand side of the radio to the **Off** position. The display will show "Key Locked On". The power and all other buttons will be disabled. This will prevent accidental operation when the radio is packed in a suitcase or carrying pouch. To release the Lock, move the Lock switch to **On** position. The display will show "Key Locked Off".

04

IMPORTANT:

Batteries should not be exposed to excessive heat such as direct sunlight, fire or the like. After use, disposable batteries should be taken to a suitable recycling center. On no account should batteries be disposed of by incineration. Do not leave batteries within reach of young children; they can be a choking hazard.

Using the AC power adaptor

1. The AC power adaptor required for this unit should be 5 volts DC at 0.8A center pin positive. Insert the adaptor plug into the DC socket on the left hand side of the radio. Plug the adaptor into a standard AC outlet. Whenever the adaptor is used, the batteries are automatically disconnected. The AC adaptor should be disconnected from the AC outlet when not in use.
2. Fully extend the telescopic antenna located on the top of your radio.
3. Press and release the Power button to switch on your radio. It may be necessary to relocate your radio to a position giving better reception. To switch off your radio, press and release the Power button.

IMPORTANT:

The AC Adaptor is used as the means of connecting the radio to the power supply. The AC Adapter used for the radio must remain accessible during normal use in order to disconnect the radio from the power supply completely, the AC Adaptor should be removed from the power supply outlet completely.

Auto clock set mode

1. Press the Power button to switch on your radio.
2. Press the Band button to select FM radio mode.
3. Press and hold the Menu button to enter the menu setting and then press the Tuning up / down button to select "RBDS Auto CT". Press the Select button to enter the setting.
4. Press the Tuning up / down button to select "Auto" or "Manual". With "Auto" selected, press the Select button to confirm the setting. Your radio will synchronize its clock time whenever it tunes to a radio station using RDS / RBDS with CT signals. The symbol "CT" will appear on the display indicating the radio time is RDS / RBDS clock time.
5. If you wish to cancel the "RBDS Auto CT" function, select "Manual" and press the Select button to confirm the setting. Please refer to the later section "Setting the clock manually" to set the clock time and date.

Note:

- If the clock time was not auto adjusted within 24 hours, the symbol "CT" will disappear on the display.
- If clock time from local RDS / RBDS station is not correct, you should consider disabling the "RBDS Auto CT" function.
- Please note that at times the RDS / RBDS signal may broadcast the wrong

11

press the Select button to change your setting.

6. After completing your EA setting, it is necessary to tune to an HD Radio station (AM or FM) which supports Emergency alerts (it is indicated with a symbol "ae" on the top of the screen), in order to receive an alert. Please note that EA can be received when the radio is in power on mode. If you want to receive the EA in the Standby mode, make sure the radio is in an environment that it can receive HD Radio broadcast signals properly and using the AC adaptor to power the radio.

Alert Volume

To adjust the Alerts volume, Press and hold the Menu button to enter the menu setting and then press the Tuning up / down button to select "Alert Volume". Press the Select button and then press the Tuning up / down button to select your required volume level. Press the Select button to confirm the setting.

Emergency Alerts History

<

